

CAST STONE SCHEDULE

MOLD NUMBER	MARK NO.	QUANTITY	WIDTH	HEIGHT	LENGTH	VOL (FT <sup>3</sup> )	WT (lbs)	REBAR
	A5	2	15 5/8"	5 5/8"	33 3/4"	1.84	248	#3 X 38" (BENT) / #3 X 28" (BENT)

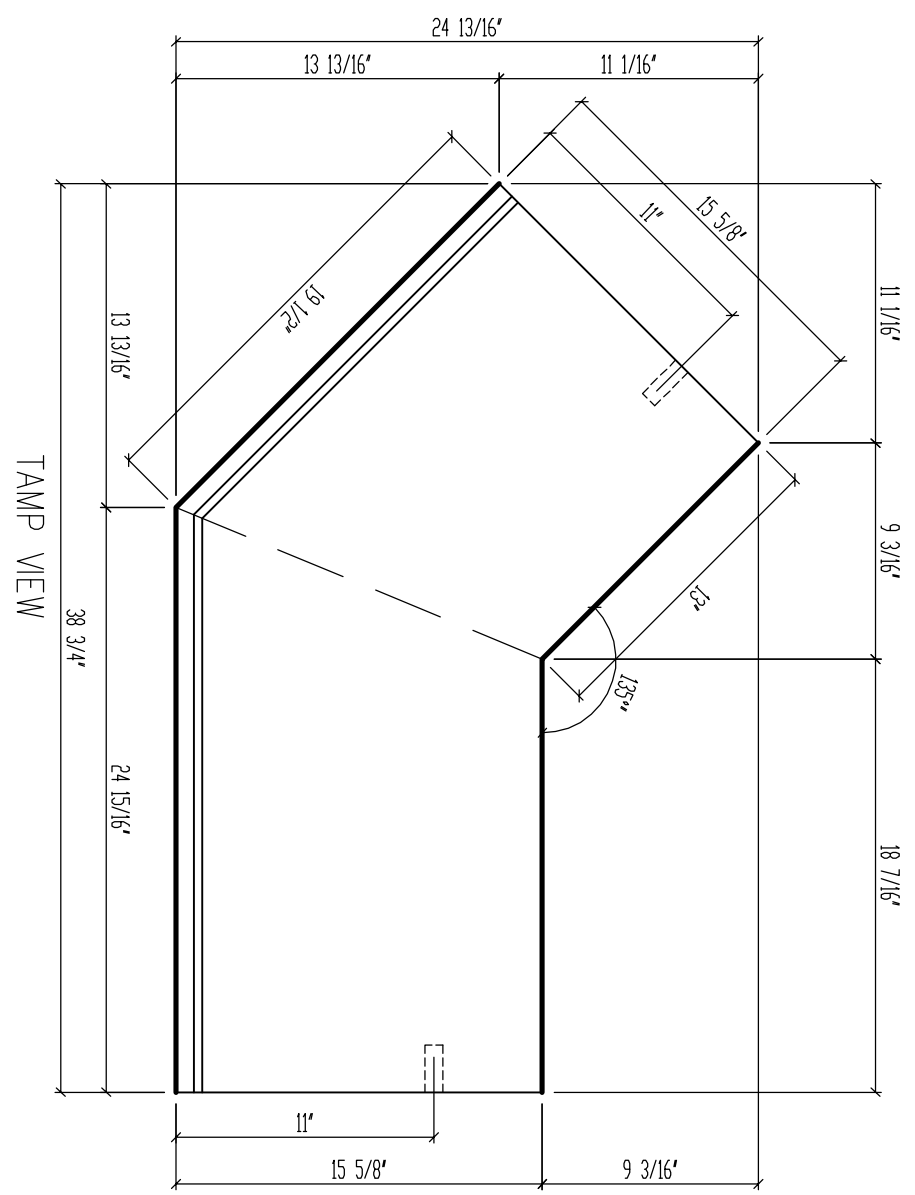

RELEASED FOR PRODUCTION

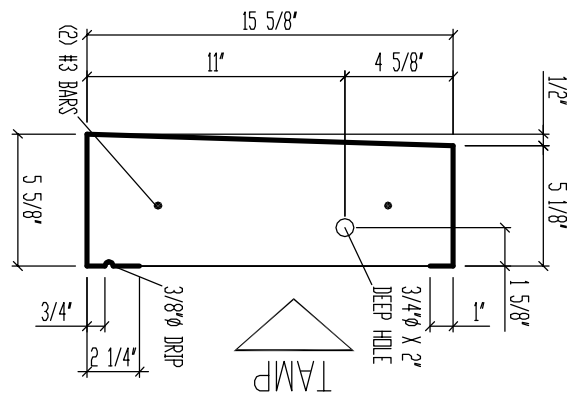
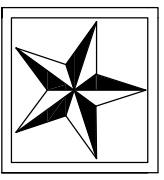

Cast Stone Systems, Inc.  
 Cast Stone & Architectural Precast Concrete  
 532 West Ridgeway Street  
 Warrenton, North Carolina 27589  
 (252) 257-1599 / 257-1588 Fax

PROJECT: DUKE/SANFORD  
 TITLE: COPING

DATE: 1/10/05  
 SCALE: NTS  
 DRAWN BY: STRIPLING DESIGNS  
 CHECKED BY:  
 PROJECT NO. 04033

DRAWING NO. A5

QUANTITY: